

# Fusing Unit Type 5000

(Code: G783)

For Machine Code: G071

## MAINTENANCE GUIDE

### Preparation

For a safe operation, read "Safety Information" in Maintenance Guide 1.

### CAUTION:

- *The inside of the machine becomes very hot. Do not touch the parts with a label indicating "▲" (means hot surface). Touching "▲" (means hot surface) could result in a burn.*
- *The fusing unit becomes very hot. When installing the new fusing unit, turn off the printer and wait about 30 minutes. After that, install the new fusing unit. Not waiting for the unit to cool down can result in a burn.*
- *Do not pull out the fusing unit forcefully. It may cause the unit to fall and result in an injury.*
- *When touching the fusing unit, do not touch any areas other than the handle as it may cause a burn.*

Replace all of the paper feed roller, friction pad and fusing unit when the following message appears on the panel display.

Replace  
Fusing Unit

### Note

- ❑ When replacing the fusing unit, replace the paper feed roller (for Tray 1) and the friction pad as well.

- ❑ Replace the friction pad and the paper feed roller before replacing the fusing unit.

Check the contents of the box for the following items:

#### ❖ Fusing Unit

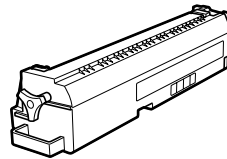

#### ❖ Friction Pad

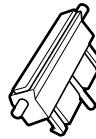

#### ❖ Paper Feed Roller

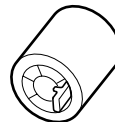

#### ❖ Gloves

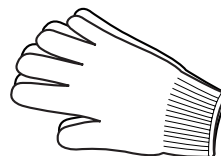

#### ❖ Fitting



#### ❖ Maintenance Guide (This manual)

## Replacing the friction pad and the paper feed roller (for Tray 1)

- 1 Turn off the printer power.

### ⚠ Important

- ❑ To prevent a burn, be sure to wait about 30 minutes after the power is turned off until the fusing unit cools down before touching the fusing unit.

- 2 Pull out Tray 1 slowly while lifting it up a little.

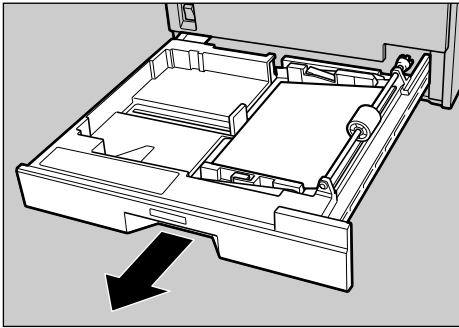

ZESH436J

The friction pad is installed as shown in the illustration.

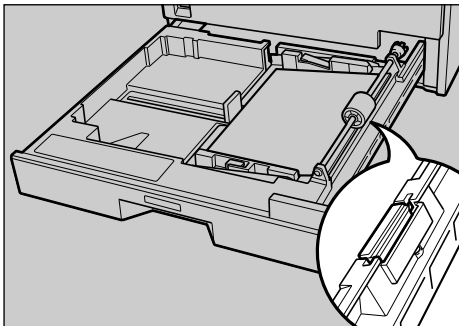

ZESH550J

The paper feed roller (for Tray 1) is installed as shown in the illustration.

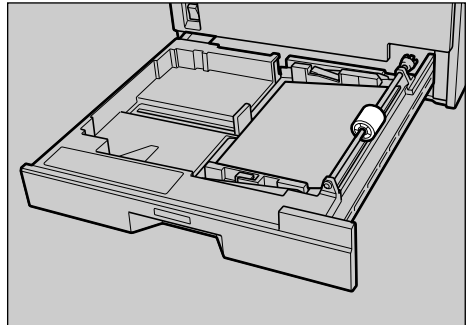

ZESH437J

- 3 Lower the base panel by pushing "Push". When paper is loaded in the tray, push down on the paper.

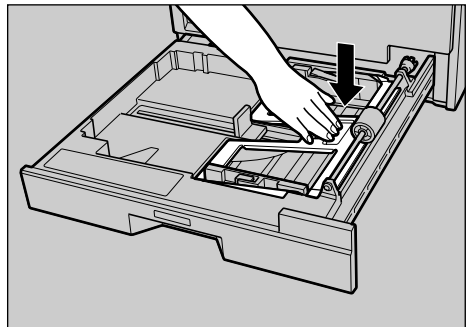

ZESH470J

- 4 When paper is loaded in the tray, remove them.

- 5 Remove the stopper (①), and then release the bar that is holding the paper feed roller by pushing towards back (②).

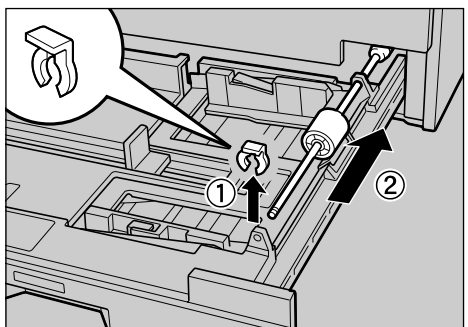

ZESH438J

- 6** Press the bar to the position shown in the illustration.

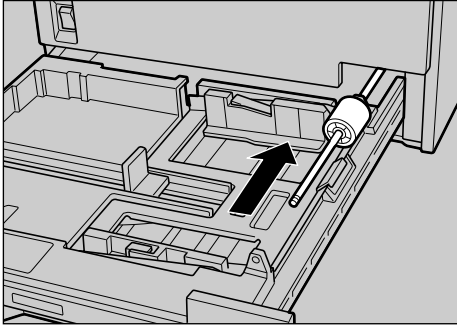

ZESH444J

- 7** Remove the friction pad by holding its sides.

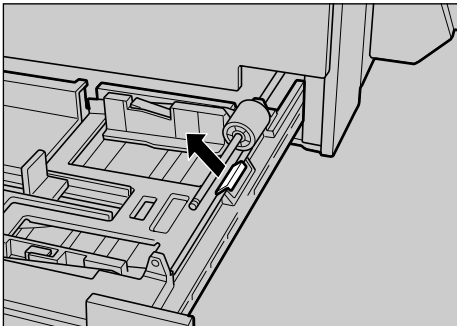

ZESH456J

- 8** Set the new friction pad by inserting its projection to the hole until it clicks.

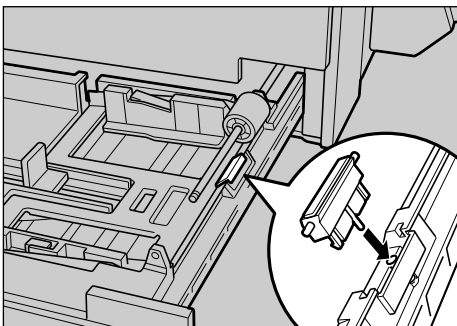

ZESH445J

- 9** Remove the paper feed roller from the bar by pulling it out (2) while pushing its stopper outwards (1).

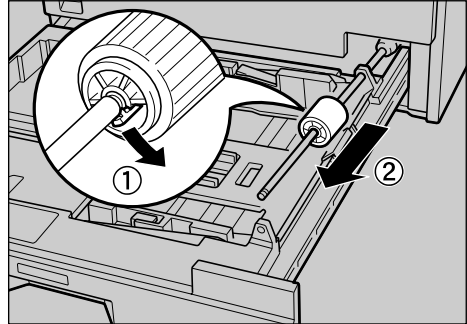

ZESH439J

- 10** Set the new paper feed roller on the bar by pushing it through with the stopper (1) facing towards you.

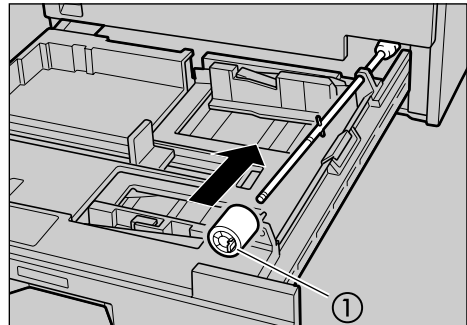

ZESH440E

**Note**

- The paper feed roller will stop at the right position.

- 11** Set the bar to the tray (1), and then set the stopper (2).

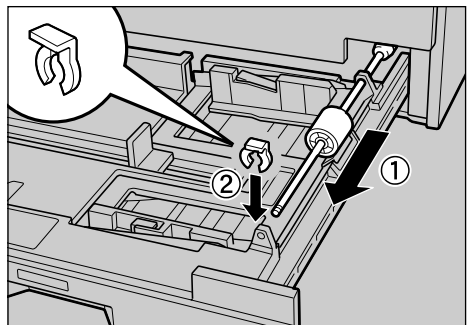

ZESH441J

- 12** Set the paper on the tray, and then close the tray firmly.

In the next step, replace the fusing unit.

## Replacing the Fusing Unit

### Important

- ❑ Confirm that the printer power is off. To prevent a burn, be sure to wait about 30 minutes after the power is turned off until the fusing unit cools down before touching the fusing unit.
- ❑ Be sure to make a setting from the control panel after replacing the fusing unit. Without it, the replacement is incomplete.

- 1** Open the front cover slowly by pulling down from the two areas on the left and right.

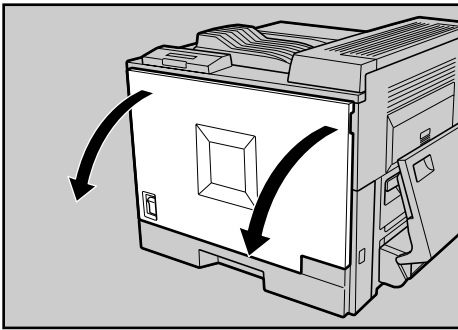

- 2** Open the Bypass Tray.

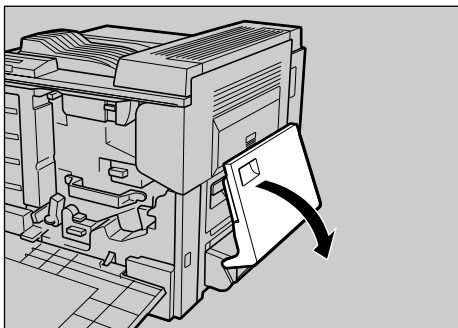

### Note

- ❑ Remove the paper on the Bypass Tray to prevent them from falling.

- 3** If the Duplex Unit is installed, open it by pushing the catch upwards.

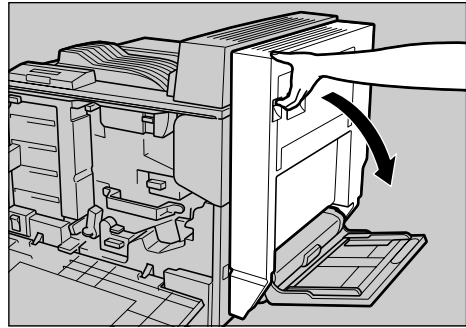

- 4** Open the right cover of the printer by pushing up the handle.

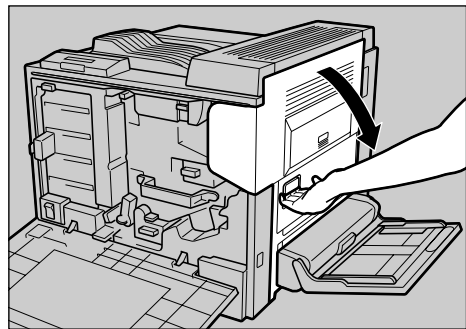

The fusing unit is installed as shown in the illustration.

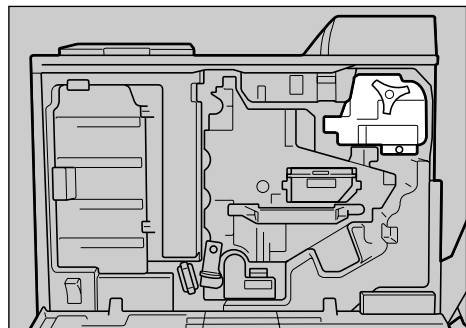

- 5** Release the green screw that is fastening the fusing unit.

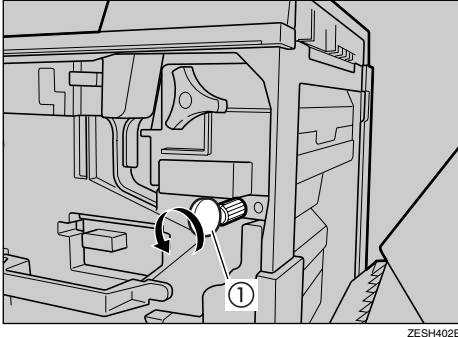

 **Note**

- Use a coin (①) to release the screw.
- The screw cannot be detached.

- 6** Put on the supplied gloves.

- 7** Holding the handle, pull the fusing unit slowly until it stops.

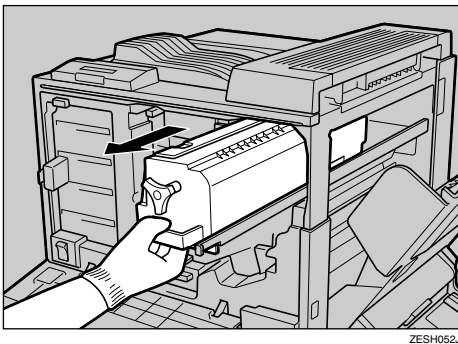

 **Note**

- Pull out the fusing unit until the whole of it can be seen.

- 8** Hold the green handles on the sides of the fusing unit with both hands, and then remove it towards the direction shown.



 **Important**

- Put the removed fusing unit on a stable, flat surface.

- 9** Take out the new fusing unit from the box. Put it on a stable, flat surface, and then remove the covering paper.

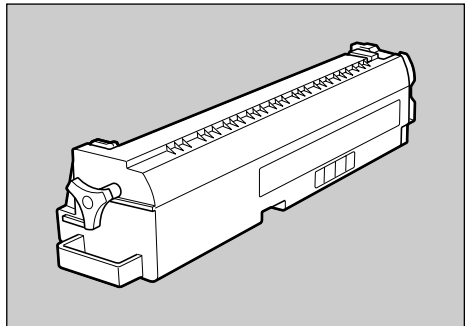

- 10** Remove the fuser oil unit from the removed fusing unit, and then set it on the new fusing unit.

- 1 Hold the green part in the center of the fuser oil unit, and then remove it from the fusing unit by lifting it in the directions shown (① → ②).

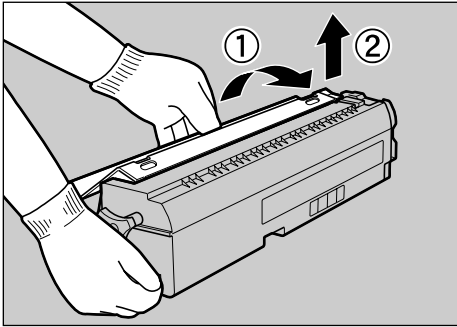

ZESH421J

### ⚠ Important

- ❑ Be careful not to let oil on the fuser oil unit get in contact with your hands or clothes.
- 2 Place the supplied fitting to the removed fuser oil unit. Hook the fitting on the fuser oil unit (①), and then insert the projection in the back of the fitting to the hole in the fuser oil unit. Next, lift the bar on the fuser oil unit lock it in the fitting (②).

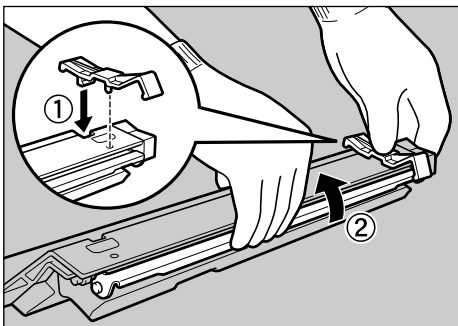

ZESH426J

- 3 Place the fuser oil unit on the new fusing unit by aligning the arrows (①), and then set it in its place (②).

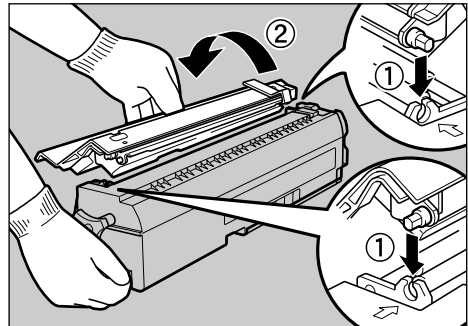

ZESH422J

- 11 Put the used fusing unit in the bag that the new fusing unit came in, and then seal the bag.
- 12 Set the new fusing unit by holding it with both hands and then aligning the guides.

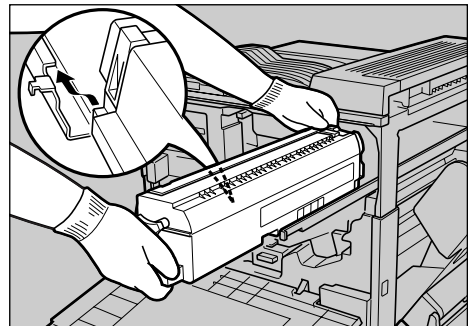

ZESH423J

- 13 Remove the fitting that you placed in step 10.

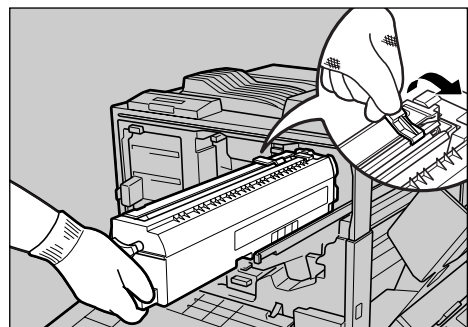

ZESH427J

- 14** Holding the handle, insert the fusing unit slowly until it stops.

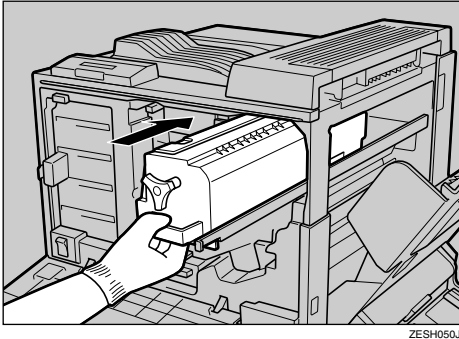

**Important**

- Do not press the fusing unit forcefully into the printer, as it may cause a printer malfunction.

- 15** Fasten the green screw tightly using a coin (1).

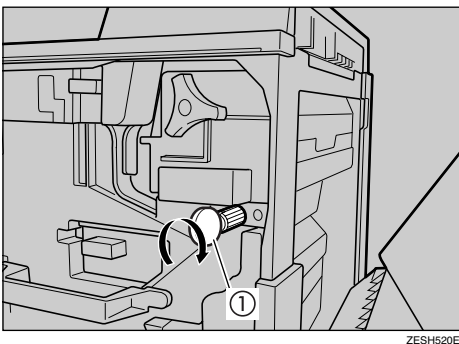

- 16** Close the right cover of the printer.

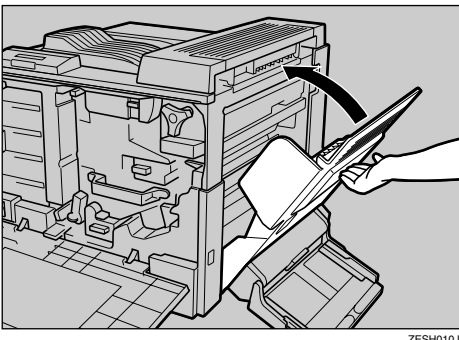

**Note**

- Press "PUSH" to close the cover firmly.

- 17** If the Duplex Unit is installed, close it.

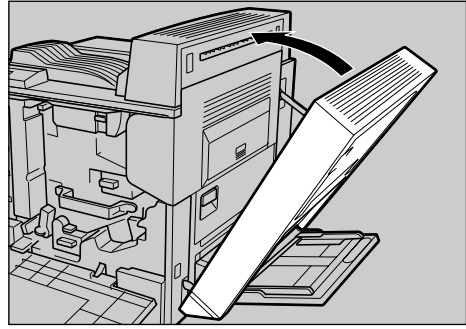

- 18** Close the Bypass Tray.

- 19** Close the front cover slowly by pushing the two areas on the left and right.

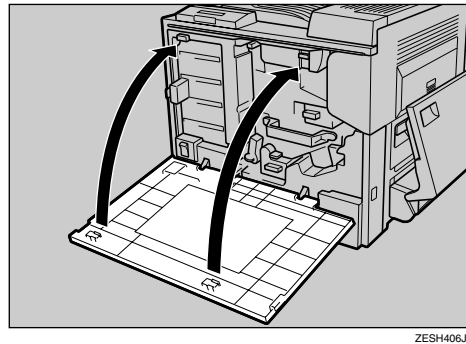

- 20** Turn on the power switch.

- 21** Make a setting from the control panel.

When Two Messages Appear on the Panel Display

- 1 When the following messages appear on the panel display, press **[Escape]** for five seconds or longer to make it disappear, and the setting will start automatically.

```
Replace
Fusing Unit
```

```
See Instructions
Before replacing
```

When Only One Message Appears on the Panel Display

```
Replace
Fusing Unit
```

- 1 Press **[Menu]**.

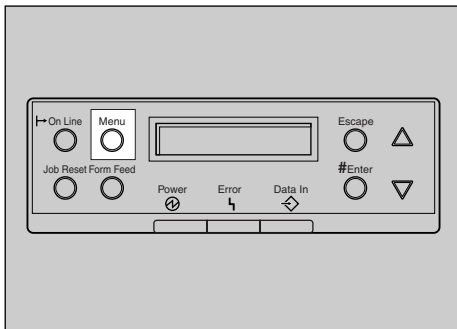

ZDJS001N

\* Panel display for North America.

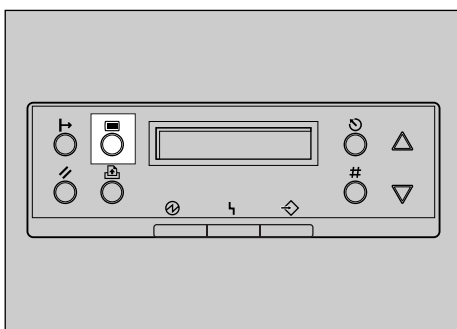

ZDJS001J

\* Panel display for Europe/Asia.

"Menu" appears on the panel display.

- 2 Press **[▲]** or **[▼]** to display "Maintenance", and then press **[Enter #]**.

```
Menu:
Maintenance
```

- 3 Press **[▲]** or **[▼]** to display "Maint. Reset", and then press **[Enter #]**.

```
Maintenance
Maint. Reset
```

- 4 Press **[▲]** or **[▼]** to display "Fusing Unit", and then press **[Enter #]**.

```
Maint. Reset
Fusing Unit
```

The following message appears.

```
Fusing Unit
Press # to Reset
```

- 5 Press **[Enter #]**. Wait for a few seconds.
- 6 Press **[On Line]**.

"Ready" appears on the panel display.

```
Ready
```